

DIMENSIONI D'INGOMBRO - OVERALL DIMENSIONS

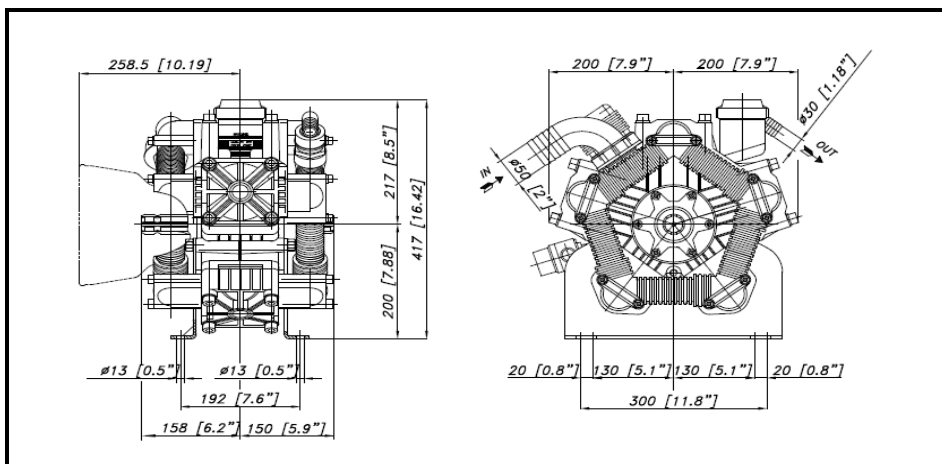

ALBERO POMPA - PUMP SHAFT

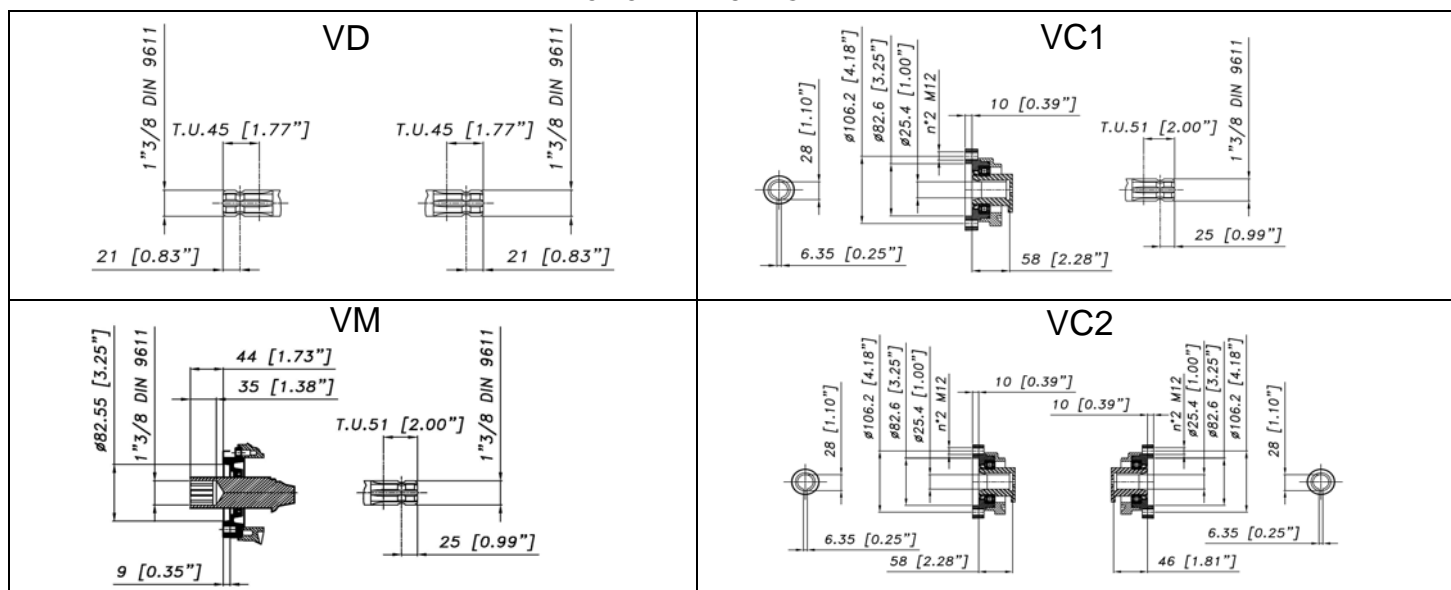

COPPIA DI SERRAGGIO - TORQUE CHART					
CODICE - CODE	Q.TY	POS	N.m	Lbr.ft	
62.9811.97.3	5	9	25	18,4	
85.2576.00.2	2	40	5 (LOXEAL 24-18)	3,7 (LOXEAL 24-18)	
86.2682.50.2	2	18	8	5,9	
86.3694.50.2	1	55	40	29,5	
86.2562.50.2	6	46	22	16,3	
86.2682.50.2	2	64	22	16,3	
86.2990.00.2	20	31	10	7,4	
86.4139.00.2	3	53	40	29,5	
86.4068.00.2	20	8	40	29,5	

Tolleranza di serraggio: 0/-10%
Tolerance on torque value:

INFORMAZIONI UTILI USEFUL INFORMATION				
LUBRIFICANTE- LUBRICANT: OLIO MOTORE O SEMIIDRAULICO SAE 30 MOTOR OIL OR SEMI-HYDRAULIC OIL SAE 30				
PRESSIONE ACCUMULATORE ACCUMULATOR PRESSURE				
PRESSIONE DI LAVORO - OPERATING PRESSURE	2 ÷ 5	5 ÷ 10	10 ÷ 20	20 ÷ 50
ACCUMULATORE ACCUMULATOR	2	2 ÷ 5	5 ÷ 7	6 ÷ 8

KIT MEMBRANE - DIAPHRAGMS KIT												
KIT	BUNA - N		DESMOPAN	VITON						PENTAX		
	1	3		1	3	29	32	5	38	1	3	
POSIZIONE ESPLOSO POSITION NUMBER	1	3	1	3	1	3	29	32	5	38	1	3
QUANTITA' NEL KIT QUANTITIES INCLUDED	5	10	5	10	5	10	1	1	5	10	5	10

KIT POMPAKIT VALVOLE - PUMP KIT/VALVES KIT																	
KIT	KIT POMPA VD VD PUMP KIT					KIT POMPA VC1/NM VC1/NM PUMP KIT					VALVOLE VALVES		VALVOLE VALVES				
	3	38	48	49	5	3	38	5	48	69	49	2	3	5	2	3	5
POSIZIONE ESPLOSO POSITION NUMBER	3	38	48	49	5	3	38	5	48	69	49	2	3	5	2	3	5
QUANTITA' NEL KIT QUANTITIES INCLUDED	10	10	1	2	5	10	10	5	1	1	1	10	#	5	10	10	5

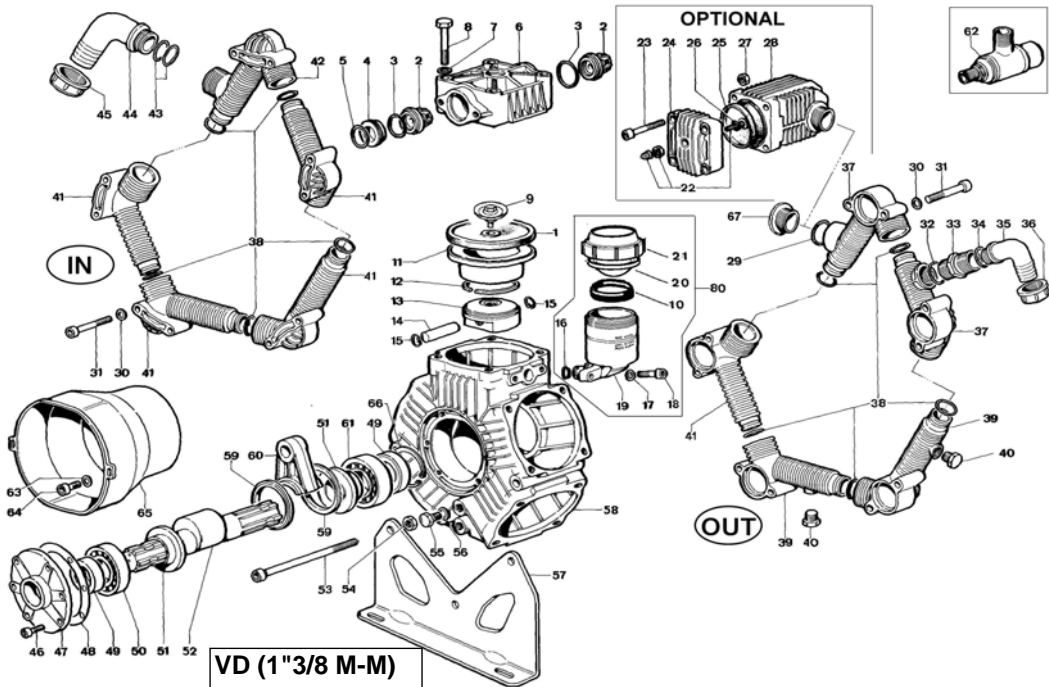

VERSIONI			
VM (1"3/8 M-F)	VC1 (1"3/8 - D.1" M-F)	VC2 (D.1" F-F)	

POS.	CODICE PART NO. REF.	DENOMINAZIONE - DESCRIPTION - DESCRIPTION	Q.TY	POS.	CODICE PART NO. REF.	DENOMINAZIONE - DESCRIPTION - DESCRIPTION	Q.TY
1	62.0040.00.2	DESMOPAN PISTON DIAPHRAGM	5	37	55.0008.32.2	MANIFOLD PIPE G.1"	2
1	62.0040.31.2	BUNA-N PISTON DIAPHRAGM (OPT.)	5	38	80.3250.00.2	O-RING 3,53X31,34	10
1	62.0040.33.2	VITON PISTON DIAPHRAGM (OPT.)	5	38	80.3250.10.2	O-RING 3,53X31,34 (KIT VITON)	10
1	62.0040.36.2	HPS PISTON DIAPHRAGM (OPT.)	5	39	55.0009.32.2	MANIFOLD PIPE G.3/8"	2
2	28.9809.97.3	S.S. VALVE ASSY	10	40	85.2576.00.2	CAP G.3/8	2
3	80.3314.00.2	O-RING 4,5x40	10	41	55.0006.32.2	MANIFOLD PIPE	5
3	80.3314.50.2	O-RING 4,5x40 (KIT VITON)	10	42	55.0007.32.2	MANIFOLD PIPE G.2"	1
4	28.0229.32.2	VALVE ASSY SPACER	5	43	80.3209.10.2	O-RING 2,62x40,95	2
5	80.3209.40.2	O-RING 2,62x44,12	5	44	84.0610.00.2	90° ELBOW CONNECTOR DIA.50	1
5	80.3209.50.2	O-RING 2,62x44,12 (KIT VITON)	5	44	84.1643.00.2	STRAIGHT CONNECTOR DIA.50 (OPT.)	1
6	62.0025.32.2	HEAD	5	45	82.0120.00.2	WING NUT G.2"	1
7	84.3844.50.2	WASHER DIA.12,2x21x2,5	20	46	86.2562.50.2	BOLT M8x20 UNI5931	6
8	86.4068.00.2	BOLT M12x75 UNI5931	20	47	14.0011.09.2	COVER	1
9	62.9811.97.3	KIT BOLT/DISK S.S.	5	48	91.0110.72.2	COVER GASKET	1
10	14.0116.32.2	SPACER	1	49	80.2143.10.2	OIL SEAL DIA.35x52x7	2
11	62.0021.01.2	PISTON SLEEVE	5	50	81.2876.00.2	BALL BEARING DIA.35x100x25	1
12	81.8540.00.2	PISTON RING DIA.78	5	51	14.0016.01.2	SHAFT SPACER	2
13	62.0018.09.2	PISTON DIA.78	5	52	14.0024.26.2	CRANKSHAFT "VD" VERSION	1
14	85.2006.70.2	PISTON PIN DIA.15	5	53	86.4139.00.2	BOLT M12x160	3
15	80.0021.00.2	RING DIA.15	10	54	81.4689.50.2	M12 UNI 5589 DACROMET NUT	3
16	80.3180.00.2	O-RING 2,62x15,08	1	55	86.3694.50.2	BOLT M12x20 UNI5931	1
17	84.3685.50.2	WASHER DIA.8,2x15x1,5	2	56	82.4079.00.2	GASKET DIA.13,2x17x1 COPPER	1
18	86.2682.50.2	BOLT M8x25 UNI5931	2	57	55.0003.61.2	MOUNTING RAIL	2
19	55.0004.32.2	OIL FILLER	1	58	55.0001.09.2	CRANKCASE	1
20	41.0017.31.2	DIAPHRAGM OIL FILLER	1	59	14.0015.76.2	CONROD RING	2
21	28.0144.32.2	OIL FILLER CAP	1	60	55.0005.11.2	CONROD	5
22	86.1608.50.2	AIR VALVE	1	61	81.2867.00.2	BALL BEARING DIA.35x80x21	1
23	86.2752.10.2	BOLT M8x35 UNI5931	4	62	24.3016.97.3	SAFETY VALVE 15bar (OPTIONAL)	1
24	11.0004.09.2	BALLASTER COVER	1	63	84.3696.00.2	WASHER DIA.8,5x24x2	2
25	23.0041.31.2	BALLASTER DIAPHRAGM	1	64	86.2682.50.2	BOLT M8x25 UNI5931	2
25	23.0041.33.2	VITON BALLASTER DIAPHRAGM (OPT.)	1	65	31.1482.32.2	PLAIN SAFETY CONE L=180 (OPTIONAL)	1
23	23.0041.36.2	HPS BALLASTER DIAPH. (OPT.)	1	65	31.1468.32.2	PLAIN SAFETY CONE L=135 (OPTIONAL)	1
26	80.3213.00.2	O-RING 3,0x6	1	66	80.1369.00.2	RING DIA.52	1
27	81.4574.50.2	NUT M8 UNI5588	4	67	85.2720.00.2	CAP G.1"	1
28	27.0035.32.2	DAMPER BODY	1	68	14.0037.07.2	CAP	1
29	80.3219.10.2	O-RING 3,0x30	1	69	80.2191.10.2	OIL SEAL DIA.45x62x7	1
29	80.3219.10.2	O-RING 3,0x30	1	70	81.2945.00.2	BEARING DIA.45X100X25	1
30	84.3685.50.2	WASHER DIA.8,2x15x1,5	20	71	14.0038.61.2	CIRCLIP DIA..45	1
31	86.2990.00.2	BOLT M8x70 UNI5931	20	72	14.0036.26.2	CRANKSHAFT "VC" VERSION	1
32	80.3219.10.2	O-RING 3,0x30	1	72	14.0039.26.2	CRANKSHAFT "VM" VERSION	1
32	80.3219.15.2	O-RING 3,0x30 (KIT VITON)	1	73	14.0111.07.2	HODRAULIC MOTOR FLANGE	1
33	83.5089.00.2	NIPPLES G.1"-G.1"1/4	1	74	80.2178.10.2	OIL SEAL DIA.40x52x17	1
34	80.3219.00.2	O-RING 3,0x25	1	75	81.2900.00.2	BEARING DIA.40x80x18	1
35	84.0560.00.2	90° ELBOW CONNECTOR DIA.30	1	77	14.0110.61.2	SPACER	1
35	84.1620.50.2	STRAIGHT CONNECTOR DIA.30 (OPT.)	1	78	14.0108.26.2	HOLLOW SHAFT "VC2"	1
36	82.0067.50.2	WING NUT G.1"1/4	1	79	86.2683.00.2	BOLT M8x25 UNI 5931	4
				80	55.9817.97.3	OIL FILLER KIT	1